

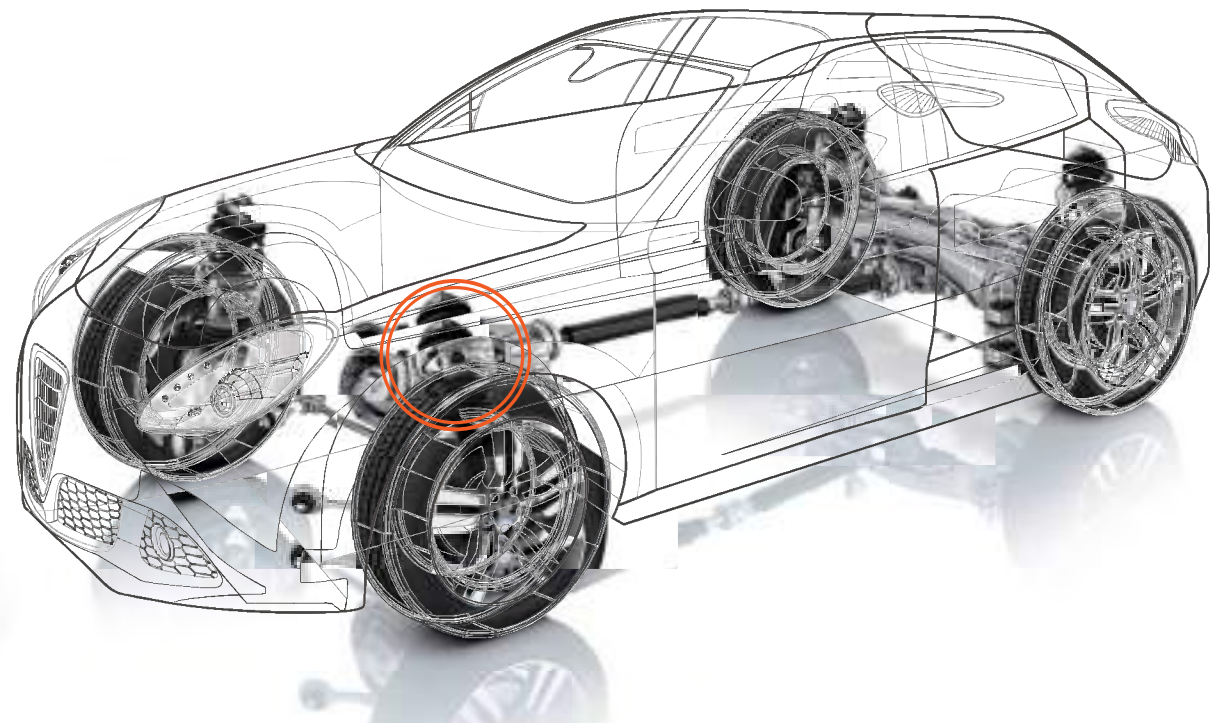

Stable cornering! Less vibration! Protect suspension!

TTC URETHANE BUFFER

Imagine a whole **different ride**



ALL ABOUT CAR

TTC CO., LTD. HAS BEEN MAKING THE MOST EFFECTS SO AS TO ACCOMPLISH THE DEVELOPMENT IN THE FIELD OF AUTOMOTIVE ACCESSORIES AND DISTRIBUTION WITH THE INGENUITY AND AGGRESSIVE LEADERSHIP.

Smotor Genuine Accessory



 **SSANGYONG PRIME VENDOR!!**

January 2014 official certification partner.

GENUINE PART NO.09AP034990



 **SSANGYONG MOTOR GENUINE ACCESSORY**

The TTC URETAHNE BUFFER is the best cushioning product in the world. It's a patented technology that combines 20 years of precise expertise. Over the last 10 years, we have been developing and upgrading our URETHANE BUFFERS to make them indestructible. TTC has an established network of partners in Korea, China, United States, South East Asia, Russia and Brazil. In 2014, TTC had entered into a formal agreement with Ssangyong to be a direct certified vendor providing URETAHNE BUFFERS for new vehicles, TTC constantly striving for further advance in new vehicle technology.

Business Vision

AS A GLOBAL LEADER, TTC IS BRINGING A NEW PARADIGM TO AUTOMOBILE INDUSTRY.

TTC CO.,LTD. have been making the best effects so as to accomplish the development in the field of auto accessories and distribution with the creative and aggressive leadership.

TTC CO.,LTD. want to be the leading company in the automobile market, looking towards the future. Our automobiles will drive people into the future.

Advancing towards the future, TTC CO.,LTD. is looking forward to be your valued partners.



Business Philosophy

Philosophy Vision

The spirit of TTC CO., LTD. is determined to challenge the world and create a better future with our customers. This has the broad meaning which is indispensable to promote the well being of our customers, to go to achieve a rich life of people in the whole world. TTC CO., LTD. will always pursue newest technologies without caring about own interests, increase the good product and better quality for our customers. By this, our “I will be together with our customers. I want to challenge the world. I create the future.” These three postulates are the code of spirit of our company TTC CO.,LTD.

We, TTC CO.,LTD. promise, that trust of our customers always will be our main goal and we will always put on the head the customer–centric thinking and chest this spirit in the future. We will strive to be the company which receive your love and attention.

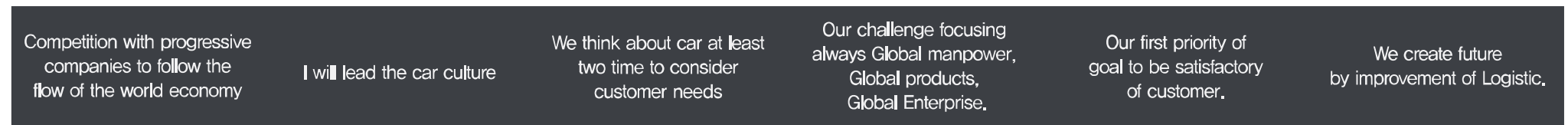

Intergrated Brand Communication

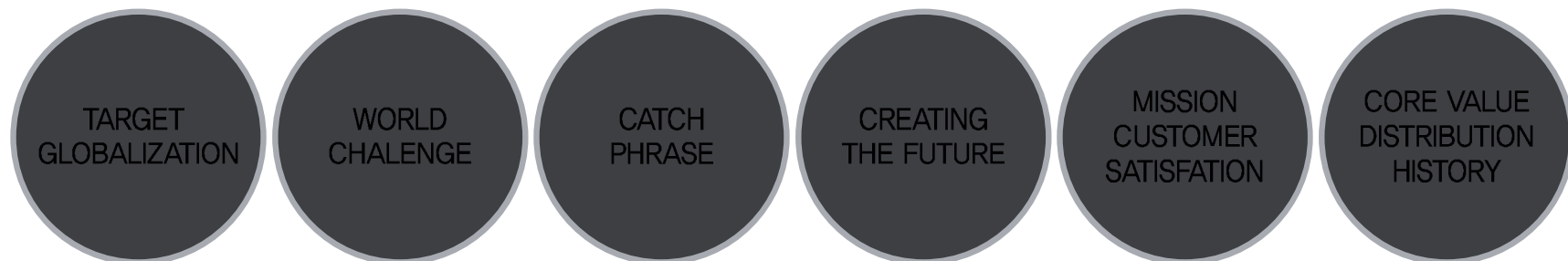

TTC URETHANE CUSHION BUFFER

TTC URETHANE CUSHION BUFFER is 100% MADE IN KOREA

TTC URETHANE CUSHION BUFFER is the product which is classified as automobile spare parts and accessory which is installed on coil spring in automobile suspension and supports suspension to enhance driving comfort and safety.



NEW TECHNOLOGY

New technology, implementing by TTC.,CO.LTD, consisted in producing the URETHANE CUSHION surface with 8~9 oval holes whose function is to disperse the neutral impulse. Our new products based on this new technology that can limit the impact on solo side to the maximum, therefore the compressive resistance is highly enhanced. As compared with the previous products, new one gives much more effective spring and the suspension system protection. As a result, it will let you have a more comfortable driving sense.



HIGH QUALITY : HIGH PERFORMANCE

TTC new material? 100% Urethane can maintain the product(the Urethane Cushion) transparency. The athletic shoes manufactured by world famous sports product company_NIKE, also utilize such kind of materials. What ' s more, mere TTC company can legally share these special materials with NIKE and TTC.



DIAMOND CUSHION

Our buffer is similar to diamond, own forever consent sheen and the beauty. You can enjoy the permanent Urethane buffer all the time!

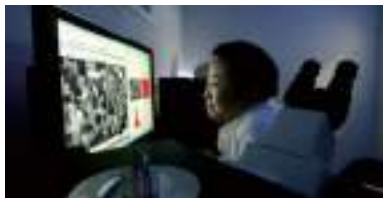

THE TTECHNIQUE TRADE SECRET OF MORE THAN 20 YEARS.

TTC company has more than 20 years to study the buffer technology specially the foundation, therefore can produce high-tech the buffer, enables you to enjoy to powerfully, more comfortable driving feeling.

ADVANTAGES OF URETHANE CUSHION BUFFER

TTC urethane cushion buffer can be minimized Front/Rear Rolling as well as Left/Right vibration due to soft suspension system and High overload frame like SUV car.



· Before (uninstallation)

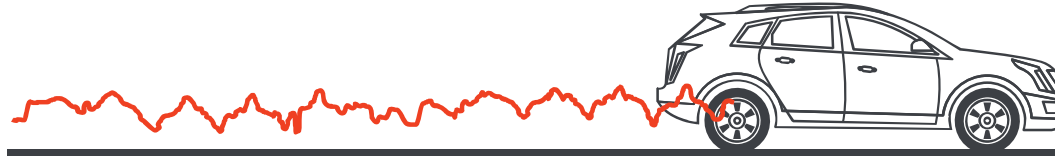

· After (installation)

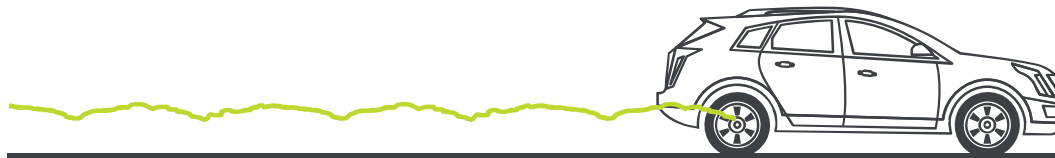

Mertis of the Product

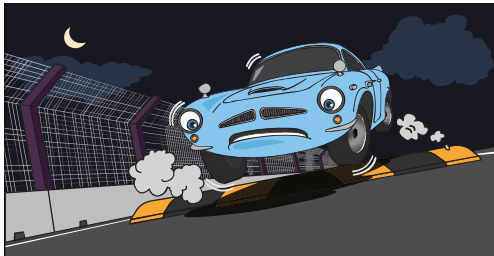

Passing over Anti-speed bar more smoothly.



To reduce inclination while sharp conering.



To protect Shock-absorber on the bumpy road.

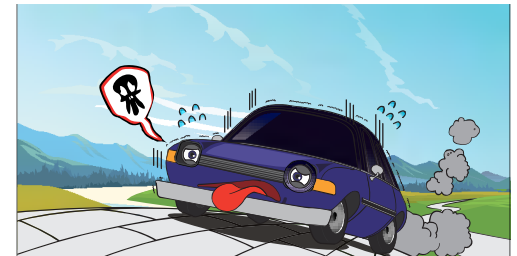

Reducing Fatigue when you drive long distance.

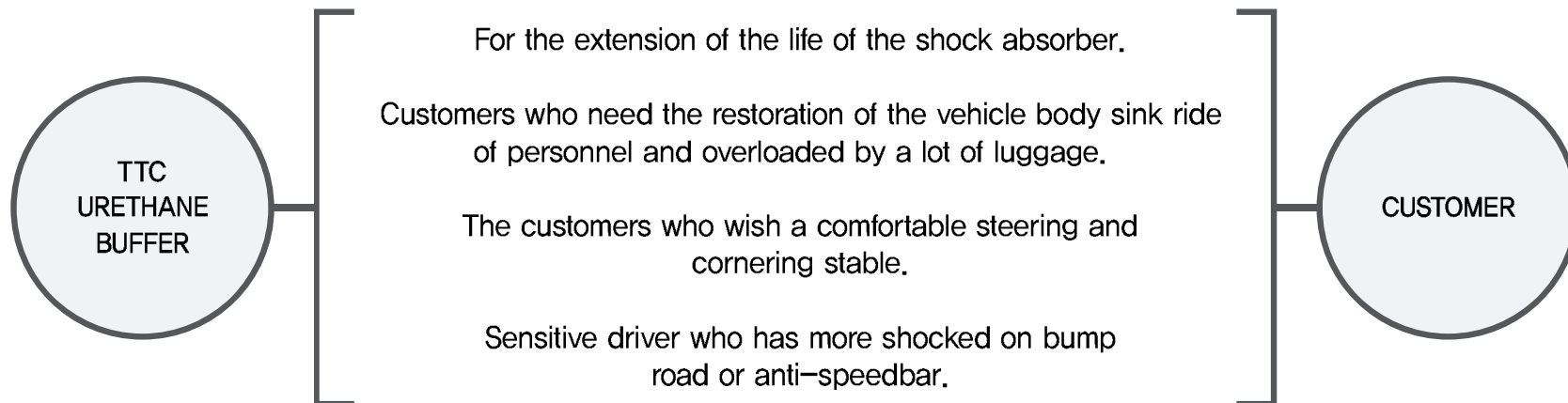

Restoration of car height



Restoration of height to be 1.5~2.5cm

After mounting height : 72,5cm

Before mounting height : 70cm



PRICING MANUAL FOR TTC DISTRIBUTOR ONLY

· Conditions of Sale and Price

Big customer or distributor who has warehouse and truck to distribute his chain store or local agent



110%

Major wholesaler who buy more than 100 set/ 6 month



Decide by local situation

Retailer and shops



Decide by local situation and to be considered installation costs

End user from internet (without installation)



200%

· Related installation costs

According to above price, You should catch more big volume sales.. You should use installation cost as 15~20 USD for car repairing center and tire change company since very easy to install after lift up and remove tire as well as it can be use to shop worker or staff as incentive of certain portion since they will become one kinds of aggressive salesman. The installation cost very useful to control your dealer.!

Internet price: Please going up more than over 165% from retail price as internet sales price this is not suggestion. We strongly asking to make internet which can be open everybody in your location to keep this regulation in accordance with exclusive contract clause.

What type of car TTC URETHANE CUSHION BUFFER?



Spring resurgence size

- 1) No driver inside car.
- 2) Be gained each coil spring height (interval) by TTC measuring gauge or ruller as above photo.
- 3) Need measuring to front and rear each once because 2 front and rear absorber using same size.



Standard of + size

As left photo, +size would be applied cut part of hole due to diameter of coil spring smaller than cushion buffer diameter while height of coil spring matching buffer size.
 A→ A+ (Cut one hole from size A)
 B++(Cut two hole from size B).

URETHANE CUSHION BUFFER STANDARD TABLE BY TYPES

Installation type of buffer differs by spring space. Check the Authenticity TTC Trademark without fail.

- Model: K/ S/ A/ A+/ B/ B+/ C/ C+/ D/ E/ F/ F+
- 1 unit car normally need 4pcs for each front and rear wheel. It is packed 2pcs for 1 same size inbox.

Buffer Model	K	S	S1	A	A+	A1	B	B+	C	C+	D	E	F	F+
Spring Space	68mm	58mm	58mm 48mm	48mm	48mm	48mm 38mm	38mm	38mm	28mm	28mm	21mm	15mm	13mm	13mm
Diameter	180mm	178mm	175mm	175mm	175mm	160mm	158mm	158mm	133mm	133mm	113mm	113mm	125mm	125mm
Height	108mm	86mm	86mm 76mm	76mm	76mm	76mm 65mm	65mm	65mm	52mm	52mm	42mm	36mm	38mm	38mm
Weight	737g	570g	584g	523g	473g	449g	383g	360g	233g	212g	168g	133g	165g	150g

Installing Method



① Prepare Buffer, jack, and soap with water (In case of Urethane Buffer, grease and oil can be used)



② Lift car up. Make sure to lift-up the car until the tire is off from the ground.



③ Then you can see that the spring is loosening.



④ Spray enough soap with water on the spring. make the spring clean.



⑤ Also spray on the groove of Buffer and then install. It's better put in the middle of the absorber.



⑥ Check whether spring is fitted well in the groove. Then lift car down, Installation complete.

- Make sure spring is fitted well in the groove. If not, it can be the cause of installation inferiority.
- When you apply Buffer that doesn't fit spring space, it can shorten durability. Please refer to the chart for selecting types of Buffer when purchasing and applying or ask to expert or contact service center..
- For the cars that fits K, S, A, B Types, fasten 2nd hole of the Buffer right/ left and up/ down loosely with cable tie after installing.

Test result of TTC URETHANE CUSHION BUFFER

Vibration Perion: 20km/h~40km/h

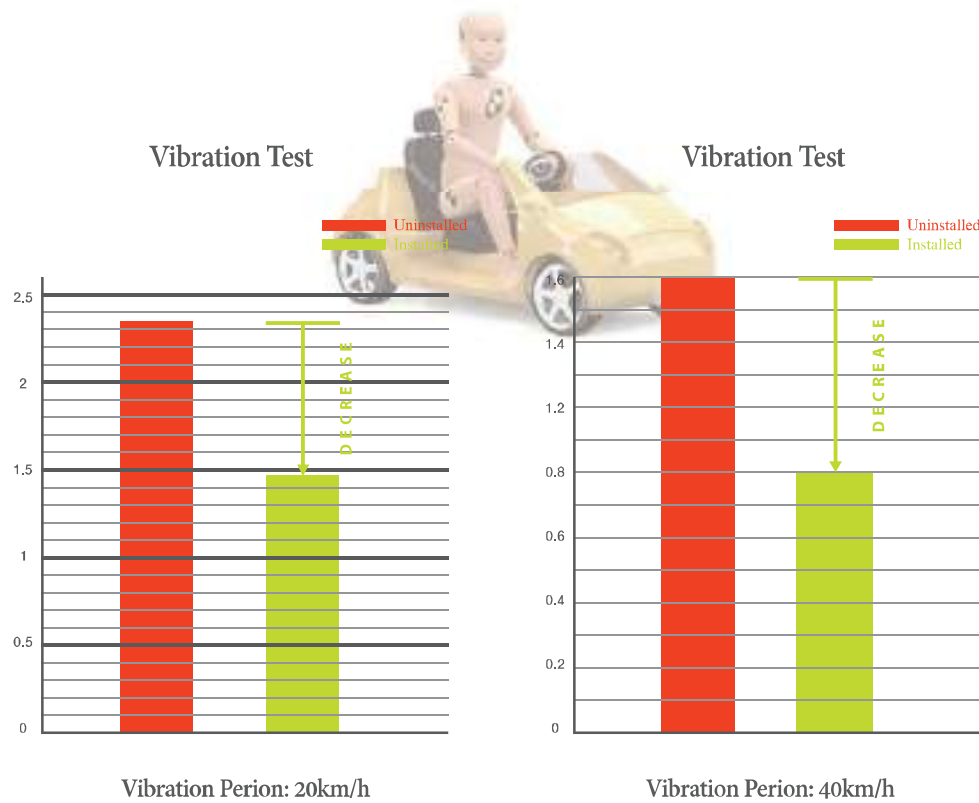

Single Lane Change

- ①Graph: Result of comparing lateral force with the sensor on the rear wheel after applying buffer shows that it less less when buffer is applied.
- ②Graph: shows that gradient of car body is relatively improved after applying buffer.

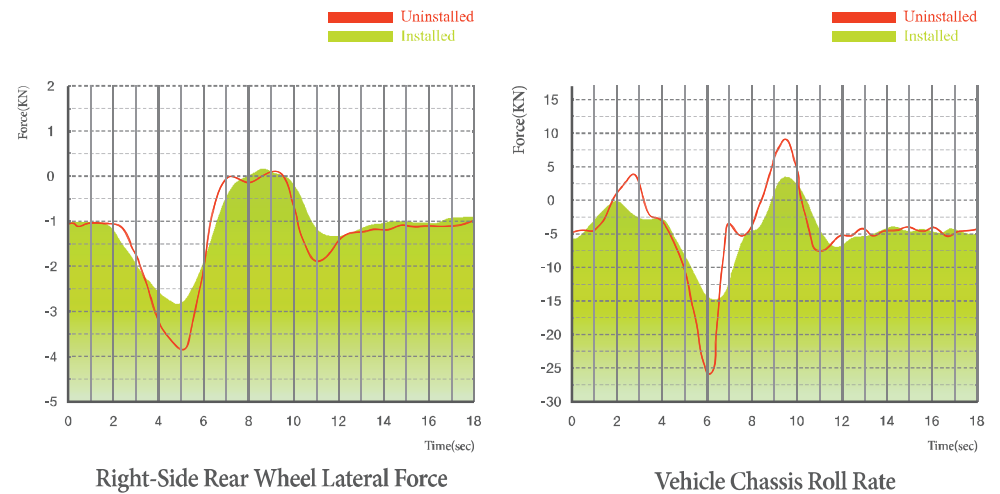

Slalom Test

- ①Graph: result of measuring lateral force on the wheel by applying sensor on the rear wheel during slalom test shows that lower force was measured on buffer applied vehicle.
- ②Graph: shows that gradient (angle speed) of car body was lowered after applying buffer.

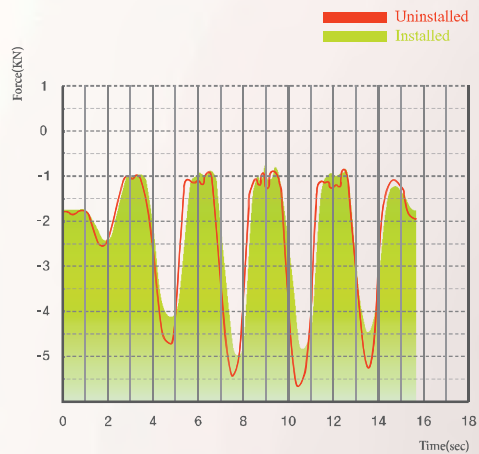

Right-Side Rear Wheel Lateral Force

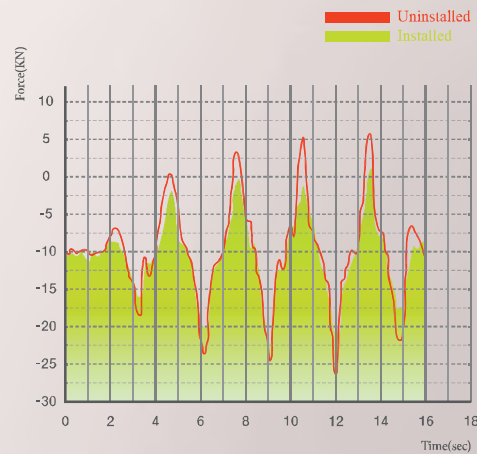

Vehicle Chassis Roll Rate

Braking Test: 80km/h

- ①Graph: Result of comparing lateral force with the sensor on the front wheel after/ before applying buffer shows that no significant differences. (Because of repetition brake to maintain high grounding force with ABS installed vehicle)
- ②Graph: shows that gradient (angle speed) of car body is relatively improved after applying buffer. (only compares Max, Min value).

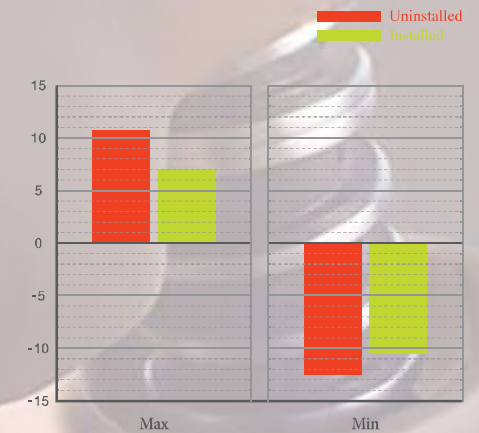
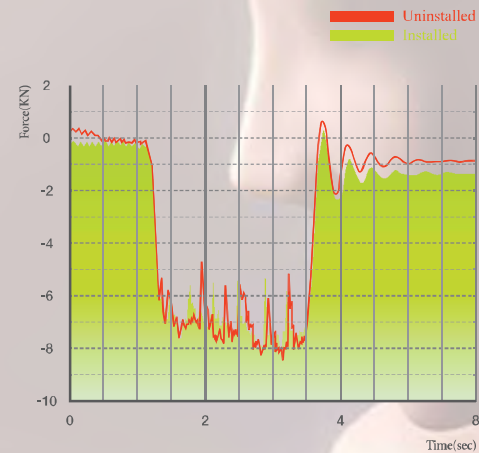

REGISTRATION & CERTIFICATION



Certificate of Venture Business



Certificate of MAIN-BIZ



Certificate of Promising Export Firm



Quality Management System Certificate(English)



Quality Assurance Certificate



Certificate of Russia Quality Standard(GOST)



Urethane Cushion Buffer Certificate of Test&Analysis Result



Certificate of Utility Model Registration



INDONESIA Certificate brand



INDONESIA Certificate of industrial design

